



REN-KMB21 / REN-KMB22 / REN-KMB25 / REN-KGS28

電焗爐

Electric Oven



僅供家庭使用
For household use only

使用說明書

OPERATION MANUAL

- 在使用本產品前，請仔細閱讀此說明書，閱讀後小心收藏保存，以備日後查閱。
Please read the operation manual carefully before using. Keep it in a safe place for future reference.
- 本說明書中的圖示可能與實物有不同的地方，僅供參考。
The images in this operation manual are for reference only and may not match with the actual product.

非常感謝您選購樂信牌電焗爐，請在使用前詳細閱讀本說明書，並保存以備日後參考。



目錄

1. 安全注意事項
2. 清潔及保養
3. 首次使用
4. 產品規格
5. 產品說明
6. 使用方法
7. 特別聲明
8. 售後服務



1. 安全注意事項

使用本產品時，必須遵守下列安全預防措施：

下圖表示由於錯誤操作而引起不同程度的危險等級。

 警告 此標誌表示可能造成傷亡。	 注意 此標誌表示可能造成傷害或財產損失。
---	--

以下不同標誌區分各種必須遵守的指示。

 此標誌表示禁止。	 此標誌表示必須遵守。
---	--

警告

- | | |
|--|---|
|  <p>為免危險，產品只適用於本說明書所註明的用途。切勿將產品或任何部份在室外使用或作其他用途使用。如錯誤操作，可造成傷害。</p> |  <p>切勿與其他高功率的電器共用同一電源插座；或超額使用電線拖板，以免電力負荷過重而導致火災及危險。</p> |
|  <p>切勿讓產品在無人看管下運作。</p> |  <p>切勿在本產品加裝定時開關或獨立的遙控系統來操作。</p> |
|  <p>切勿烤焗塗有過量牛油或果醬的麵包或在烤盤上塗過多油，否則引起濃煙或火災。</p> |  <p>切勿將易燃物料或密封容器放入產品中進行烤焗。切勿將易燃物料放於爐腔內儲存，以免導致起火。</p> |
|  <p>切勿把本產品、電源線或插頭浸入水中；或被水濺濕，以免造成觸電或火災。</p> |  <p>手濕時切勿接觸、插入或拔除插頭，否則可構成觸電的危險。</p> |
|  <p>烤焗會釋出油脂或有醬汁的食物時（如生肉、魚、炸物等），請用錫紙包裹食物及放於烤盤上，避免因食物油脂或醬汁濺到發熱管而起火。</p> |  <p>確保錫紙或焗爐紙沒有接觸到發熱管，以免發生火災。請注意錫紙及焗爐紙可能會因烹飪時間和環境而起火。</p> |
|  <p>切勿使用有殘缺或鬆動的插座。使用前，確保插頭已充分擦乾及已插穩。</p> |  <p>切勿擅自改裝產品或使用非生產商提供的原裝零件進行修理，否則可能造成危險及維修保養將無效。</p> |

警告



確保本產品的電源線沒有貼近爐身，否則電源線的絕緣材料或會熔化，造成短路的危險。



使用後，應將插頭從插座內拔出，以免因絕緣老化而發生漏電。



經常檢查產品、電源線及插頭，如有損壞或產品曾跌落，為避免危險，應立即停止使用，並聯絡信興電器服務中心有限公司安排檢查及維修。



切勿在以下環境使用本產品：

- 潮濕或接近水的環境
- 被陽光直接照射或靠近熱源或高溫環境如煮食爐
- 在不平穩的表面上
- 易燃物料或不耐熱物品附近 (如枱布、窗簾及毛巾等)

注意



產品上此符號(左圖)表示使用時表面會變熱，切勿觸摸。



如長期不使用，發熱管可能會積聚油漬，再次使用時可能會產生大量油煙，此乃正常現象。



打開爐門時務必小心，避免造成爐門玻璃或手柄損壞。



使用時或剛使用後，切勿用冰冷的濕布清潔爐門玻璃，以免玻璃爆裂。



請確保產品上方必須保持30厘米；四周及背面必須保持10厘米的散熱空間及平放，以確保產品保持空氣流通，切勿在牆櫃或櫥櫃使用及堵塞通風口。



可觸及的部件(例如：外殼、爐門、烤盤、烤網或發熱管等)在使用過程中可能會變熱。應避免接觸灼熱部分並應使用隔熱手套，以免燙傷。



如產品發生冒煙或起火現象，請保持爐門緊閉，以免因遇上空氣而加大火勢。在安全的情況下，立即拔去電源插頭或關掉屋內電源總開關。切勿用水滅火，以免玻璃門爆裂。



此產品可供年齡在8歲或以上的兒童及體質、感覺或智力有障礙人士或缺乏經驗和相關知識的人士使用，但他們必須接受負責安全人士的監督或指導如何安全地使用產品和理解所涉及的危險。









為避免玻璃破裂及危險，切勿在爐門上拖拉容器。



切勿讓小孩在沒有監督指導下單獨清潔及維修保養本產品。監督兒童不可將產品當作玩具。將本產品及其電源線放於小孩不能接觸的地方。

注意

- | | |
|--|--|
|  切勿在電源線纏結的情況下使用或將電源線懸掛在桌子、櫥櫃的邊緣或讓它接觸發熱的表面，否則會損害電源線。 |  此產品只可供家庭或類似環境使用，如商戶內部、辦事處和其他工作環境的員工廚房區域；旅館、汽車旅館和其他住宿類型的環境。 |
|  切勿在電源線上放重物、夾住、改裝、用力拉扯或扭曲電源線。 |  在插入或拔除插頭時，應手握穩插頭本身，不要抓住電源線。 |
|  切勿將物件或剛取出的加熱容器擺放在打開的玻璃爐門上。 |  使用後，請拔出插頭及待冷卻後才移動、清潔或檢查產品。 |

2. 清潔及保養

1. 清潔前，必須拔除電源插頭及等待產品及其配件冷卻。
2. 保持爐腔清潔。每次使用後，必須在產品處於微溫時用溫水清潔外殼及爐腔。如濺出的食物渣滓或液體殘留在爐腔內，應先以濕布抹淨，再抹乾。如爐腔十分骯髒，可用軟綿布沾上溫和清潔劑擦拭，並用濕布抹淨。
3. 每次使用後，必須清潔烤盤、烤網、烤叉組件及碎屑盤，避免油脂或食物渣滓積聚導致使用時產生油煙、引起火災或造成侵蝕生銹。
4. 清潔配件時，切勿使用冷水急速降溫，以免造成變形。用軟布或海綿沾上溫和清潔劑，再用清水沖洗及擦乾。使用前必須確保產品、插頭及所有配件抹乾。
5. 爐腔底部有活動碎屑盤，可拉出進行清潔。清潔後，必須裝回原位才可使用。
6. 清潔產品後，可將溫度旋鈕設定在250 °C，功能旋鈕設定在 ，時間旋鈕設定為10分鐘，以排除所有水份，避免造成侵蝕生銹。
7. 切勿擦拭發熱管。
8. 切勿使用粗糙的潔具(如鋼絲刷)、有毒或含腐蝕性的清潔劑進行清潔。
9. 鹽份是具侵蝕性的物質，一旦積聚在爐腔內，將形成銹漬。一些帶酸性的醬汁，例如茄汁、芥末和醃製食品含有氯和酸的化學成份。而該等成份會對爐腔表面造成影響。所以每次使用後，必須進行清潔。
10. 爐腔有變黃現象，因為金屬受熱作用下產生的黃色印記，這屬於正常現象，既不影響使用，也不會對人體產生危害。
11. 缺乏適當清潔產品，會使產品表面劣化，影響產品的使用壽命及可能會造成危險。
12. 儲存時，請將產品放入紙箱及放置在乾爽的環境中。
13. 儲存時，切勿將電源線纏繞在產品四周或壓住電源線，避免造成電源線損壞。

3. 首次使用

首次使用前，請按以下步驟進行空燒以清除新機氣味：

1. 取出所有配件，並用清水洗淨及擦乾。
2. 連接電源前，請檢查功能旋鈕及時間旋鈕在OFF(關) 的位置。
3. 連接電源，將溫度旋鈕設定在250 °C，功能旋鈕設定在 ，時間旋鈕設定為10分鐘，空燒時可能有煙、氣味及發出聲響，此屬正常現象。
4. 空燒後，必須待產品冷卻後，才可再次使用。

4. 產品規格



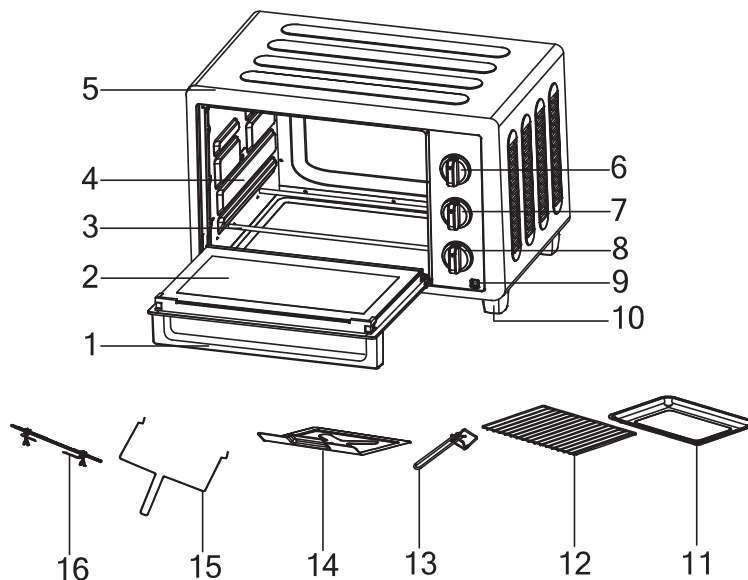

型號	REN-KMB21	REN-KMB22	REN-KMB25	REN-KGS28
額定電壓	220-240伏特~ 50/60赫茲	220-240伏特~ 50-60赫茲	220-240伏特~ 50/60赫茲	220-240伏特~ 50/60赫茲
額定功率	1,380瓦特	1,500瓦特	1,500瓦特	1,500瓦特
容量(約)	21升	22升	25升	28升
溫度控制	最高位250°C(±30°C為正常範圍)			
淨重(約)	5.9公斤	5.8公斤	6.0公斤	6.7公斤
爐腔尺寸* (闊x 深 x 高) (約)	316 x 280 x 240 毫米	324 x 285 x 256 毫米	324 x 336 x 253 毫米	347 x 295 x 265 毫米
產品尺寸 (闊x 深 x 高) (約)	460 x 335 x 291 毫米	463x356x308 毫米	463 x 393 x 309 毫米	498 x 365 x 328 毫米

* 爐腔容量是根據最大闊度、深度和高度而計算的，實際存放食品的容量稍少於此值。

5. 產品說明



(各型號產品在外觀上稍有不同，但結構大致相同。此產品圖僅供參考，請以實物為準。)

1. 爐門門柄: 用於開關爐門。
2. 爐門玻璃: 可透過爐門玻璃查看食物烤焗情況。
3. 發熱管: 產生熱能烤焗食物。
4. 層軌: 承托烤盤及烤架。
5. 本體
6. 溫度旋鈕: 溫度設定範圍為100°C-250°C。
7. 功能旋鈕:
 - OFF : 關掉發熱管。
 -  : 下烤 + 熱風對流。
 -  : 上下烤。
 -  : 上下烤 + 旋轉烤焗 + 熱風對流。
 -  : 上烤 + 旋轉烤焗。
 -  : 上烤 + 熱風對流。
8. 時間旋鈕: 順時針旋轉至所需烹調時間, 時間設定範圍為(OFF) 0-60分鐘, 完成烹調時會有提示聲。
9. 電源指示燈: 由時間旋鈕控制, 設定烤焗時間後, 指示燈會亮起, 烤焗時間完結, 指示燈才會熄滅。
10. 爐腳
11. 烤盤: 承載魚及肉等會釋出油脂或有醬汁的食物。建議鋪上錫紙再將食物放在烤盤上烤焗, 以便容易清洗。最大承載重量是2.5公斤(包括食物和餐具)。
12. 烤網: 承載乾性食物, 如馬鈴薯及麵包等。最大承載重量是2.5公斤(包括食物和餐具)。
13. 烤盤夾: 用於取出烤盤或烤網, 使用方法如下圖示:

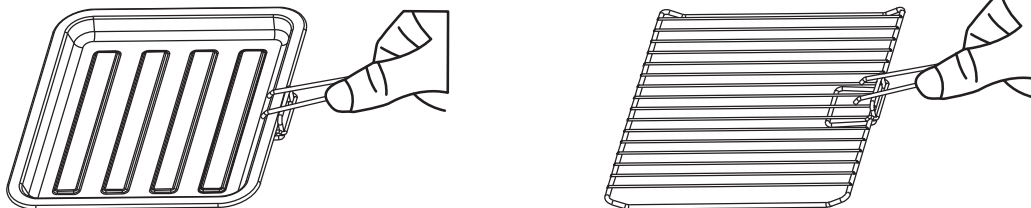

14. 可拆式碎屑盤: 放置於下發熱線下方, 用於承載食物殘渣及油脂。每次使用後必須清潔, 以免殘渣過度烤焗產生異味。
15. 烤叉托架: 用於取出烤叉組件。
16. 烤叉組件(1條烤叉軸 + 2條烤叉 + 2個螺絲): 用於旋轉烤焗。最大承載食物重量是2.5公斤。

6. 使用方法

1. 將配件取出，並把電源插頭插入插座。(提示：先將產品預熱10-15分鐘，可達至更理想的烤焗效果。)
2. 將食物平均地放置在烤網或烤盤上，再插入爐腔內適當的層軌。如烹調會釋出油脂或有醬汁的食物時，用錫紙包裹食物再放在烤盤上。如使用烤網，確保食物不會從烤網跌出。如食物比較細小，可放在烤盤上烤焗。須放好食物後才關上爐門。
3. 轉動功能旋鈕以選擇烤焗模式。以下是各烤焗功能建議可烹調的食物，用戶亦可跟據個人烹調經驗選擇。

功能	建議可烹調的食物
	烤焗麵包、比薩和肉類等。
	需要旋轉燒烤的家禽、肉串等

使用旋轉燒烤時，請注意以下事項：

- 3.1 烤叉比較尖銳鋒利，小心使用，以免受傷。
- 3.2 將烤叉穿入烤叉軸，在合適位置旋轉螺絲固定烤叉。
- 3.3 將烤叉軸貫穿食材，並用烤叉固定一邊。
- 3.4 將另一個烤叉穿入烤叉軸，插緊食材，再旋轉螺絲固定另一烤叉。
- 3.5 使用烤叉托架，將穿好的食材放入產品。
- 3.6 將烤叉彎頭一端插入爐腔右側孔位，再將平頭一端放在爐腔左側凹槽上。

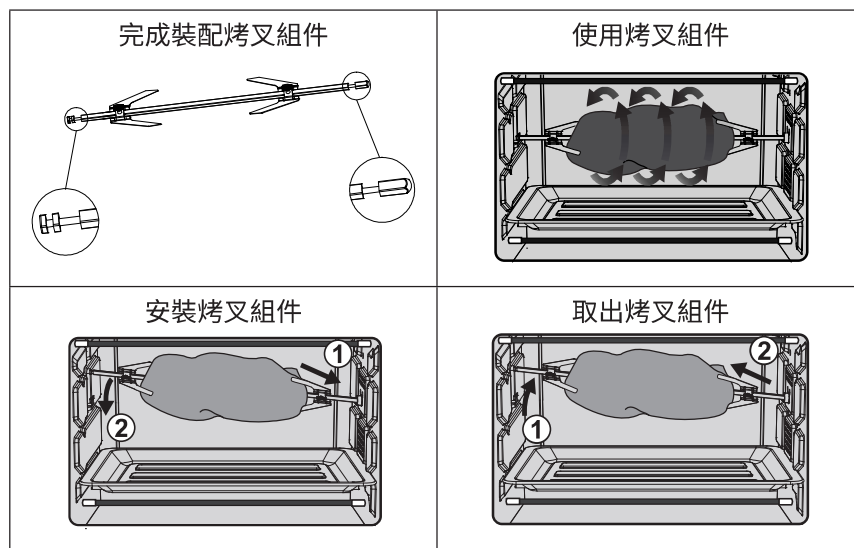

4. 根據食材的屬性及個人喜好，轉動溫度旋鈕設定烹調溫度。
5. 將時間旋鈕設定到所需的烹調時間，電源指示燈會亮起。如烤焗時間少於5分鐘（例如：3分鐘），請旋轉至超過6分鐘再回轉到所需時間。
6. 當預設烤焗時間完成後，產品會發出鳴聲提示，時間旋鈕會轉到“OFF”的位置。請將功能旋鈕設定到“OFF”的位置以關掉產品。（提示：如需要在烹調過程中關掉產品，可將時間旋鈕及功能旋鈕轉到“OFF”的位置。）
7. 當檢查或移動在產品內的食物時，請使用耐高溫的隔熱手套、烤盤夾或烤叉托架，以免燙傷。
8. 使用後，請把電源插頭從插座拔出。

烹調注意事項：

1. 冷凍過的食物需要較長的烤焗時間，請根據實際烹調情況調整烤焗時間。
2. 烹調時間因食物的溫度、種類、份量等不同而各有差異，請根據實際情況進行調整。
3. 時常留意烤焗中的食物，避免烤焦。
4. 烤焗時，水蒸氣可能會凝聚於爐門周邊或玻璃上。這是由於食物當中的水分蒸發所造成，此為正常現象。
5. 為調整爐內溫度，發熱管備有自動切換電源裝置，當爐溫達到預設溫度時，發熱管會暫時停止加熱，待爐溫下降後便會恢復運作。切勿在烤焗中途將食物取出，否則會出現加熱不足的情況。
6. 使用時，產品可能有聲音發出，這是由於加熱時物料和食物膨脹，並不表示發生故障。
7. 如烹調過程產生大幅度的溫度變化、食物過重及排列不均勻，都可能令配件變形。

7. 特別聲明

1. 本資料上所有內容經過核對，如有任何印刷及內容上的誤解，本公司將保留解釋權。
2. 本產品若有技術改進，會編進新版說明書中，恕不另行通知；產品外觀、顏色如有改動，則以製造商資料為準。
3. 如本資料之中英文版本有差異時，應以中文版為準。
4. 使用說明書的電子副本可以通過電子郵件發送致客戶，如有需要，可致電信興電工工程有限公司：2861 2767。

8. 售後服務

1. 由購買收據日期起之一年保修期內，經信興電器服務中心有限公司之服務人員證實產品故障屬於正常使用之情況下發生者，本公司將提供免費維修或更換零件服務。經更換之任何損壞零件，將歸屬本公司所有。保修範圍不包括修理或更換產品之損耗性零件等。
2. 用戶必須於維修時出示購買收據／換購收據及蓋有銷售點／換購中心印章的產品保修記錄卡。如有任何疑問，請致電信興電器服務中心有限公司熱線：2406 5666查詢。

Thank you for choosing Rasonic Electric Oven. Please read the operation manual carefully before use and keep it for your future reference.

Table of Contents



1. Important Safeguards
2. Cleaning and Care
3. First Use
4. Product Specifications
5. Product Descriptions
6. Operation Instructions
7. Special Avowal
8. After Sales Service

1. Important Safeguards









When using the appliance, please follow the below safety precautions:
The following chart indicates the degree of damage caused by wrong operation.

 WARNING	 CAUTION
Indicates that may cause death or severe injury.	Indicates hazards that may cause human injuries or property damages.

The following symbols can distinguish the instruction types that need to be strictly followed.

	
These symbols mean prohibition.	These symbols mean requirement that must be followed.

WARNING

- | | |
|--|--|
|  To avoid danger, use the appliance only as described in the operation manual. Do not use it or any part of the appliance outdoors or out of the intended purpose. Misuse can cause potential injury. |  Do not use the same socket with other high power consumption appliance or use the extension cord beyond its capacity to avoid fire and danger caused by overload. |
|  Never leave the appliance unattended when in use. |  The appliance is not intended to be operated by means of an external timer or separate remote control system. |
|  Do not toast bread with too much butter or jam or spread too much oil on the bake tray, or it may cause smoke or fire. |  Never put inflammable materials or sealed containers into the appliance for cooking. Never put inflammable materials in the oven cavity for storage, otherwise a fire may be caused. |
|  Never immerse the appliance, power cord or plug in water or let them wet, it can cause electric shock or fire. |  Do not touch, plug in or remove the plug with wet hands, it can cause electric shock. |



WARNING



When cooking foods which are greasy or marinated with sauce (e.g. raw meat, fish, deep-fried food, etc.), please wrap the food with aluminum foil and put them on the bake tray. It is to avoid the food grease or sauces from spilling onto the heat elements and cause fire.



Make sure the aluminum foil or cooking sheet does not touch the heat elements to avoid fire. Also, please note that the aluminum foil and cooking sheet could start a fire depending on the cooking time and conditions.



Do not use deficient or loosen socket. Before use, make sure the plug is dry and inserted firmly.



Do not attempt to modify the appliance by yourself or repair with any unauthorized parts, otherwise it will cause hazards and the warranty will become invalid.



Make sure the power cord is not in contact with the oven enclosure. Otherwise, insulating material of the power cord may melt resulting in a risk of short circuit.



Always unplug the appliance from the power socket after use to avoid electric leakage due to insulation parts degeneration.



Always check the condition of the appliance, power cord and plug. To avoid hazards, if any damage is found or the appliance had fallen, stop using the appliance immediately and contact Shun Hing Electric Service Centre Ltd. for checking and repairing.



Do not operate the appliance in following places:

- Humid environment or near water
- Expose to sunlight or near heat sources or high temperature place such as cooker
- Unstable surface
- Near inflammable or non-resistant to heat objects (e.g. table cloth, curtain and towel etc.)



CAUTION



This symbol (shown on the left) on the appliance means the surfaces are liable to get hot during use, do not touch.



If the appliance is not in use for a period, grease may accumulate on the heating element. Excessive smoke may occur when it is used again which is normal.



Be caution when opening the oven door, to prevent damage to the door glass or door handle.



Do not clean the door glass by cool cloth during operation or just right after operated to prevent glass crack.



Make sure there is at least 30 cm clearance on the top and at least 10cm clearance on its surrounding and back for good ventilation and the appliance must be placed level. Do not operate the appliance under a wall cupboard or shelf and block the ventilation opening.



The temperature of accessible surfaces (such as the enclosure, door, bake tray, grill rack or heating element, etc.) may be high when the appliance is operating. Care should be taken to avoid touching heated parts, always wear the oven gloves to avoid getting burns.











If the appliance smoke or catch fire, keep the oven door closed as air will trigger the fire to burn more vigorously. Unplug it from the power socket at once or turn off the main switch under a safe situation. Never try to put out the fire with water to avoid the glass door crack.



The appliance can be used by children aged from 8 years and above and persons with reduced physical, sensory or mental capabilities, or lack of experience and knowledge, unless they had been given supervision or instruction concerning use of the appliance in a safe way and understand the hazards involved.



CAUTION

- | | |
|--|--|
|  To avoid glass crack and danger, do not drag the container along the oven door. |  Cleaning and user maintenance shall not be made by children without supervision. Children being supervised not to play with the appliance. Please put the appliance and its power cord in a place not reachable by children. |
|  Do not operate the appliance when the power cord is tangle or hang the power cord over the edge of a table, counter-top or let it touch any hot surface, it may damage the power cord. |  The appliance is intended to be used in household or similar applications such as staff kitchen area in shops, offices and other working environments; by clients in hotels, motels and other residential type environments. |
|  Do not place heavy objects on the power cord. Never clip, modify, stretch or twist the power cord. |  Grasp the plug itself when plug in or unplug the appliance, do not grasp the power cord. |
|  Never put objects or heated container just taken out from the oven on the opened glass door. |  After use, please unplug the appliance and let the appliance cool down before moving, cleaning or checking. |

2. Cleaning and Care

1. Before cleaning, must unplug the appliance and wait for the appliance and its accessories cool down.
2. Keep the oven cavity clean. After each use, must clean the oven surfaces and cavity with lukewarm water. When food splatters or spilled liquids adhere to the oven cavity, wipe with a soft damp cloth, then wipe it dry. If the oven cavity gets very dirty, clean with a soft cloth soaked with mild detergent, then wipe it clean with a wet cloth.

3. After each use, must clean the grill rack, bake tray, rotisserie spit and crumb tray to avoid smoke, fire or metal erosion caused by the accumulated grease or food residue.
4. When clean the accessories, do not rapid cooling them by cold water to avoid deformation. Use a soft cloth or sponge soaked with mild detergent, then rinse them and wipe them dry. Always make sure the appliance, power plug and all accessories are dried before use again.
5. A removable crumb tray is at the bottom of the cavity that can be pulled out for cleaning. Make sure it must be put back in place before use.
6. After clean the appliance, set the temperature knob at 250°C, the function knob at , the timer knob at 10 minutes. It is to eliminate all the moisture to prevent metal erosion.
7. Never rub the heat elements.
8. Never clean with harsh cleaning tools (e.g. metal-wired brush), or use poisonous or corrosive detergent to clean.
9. Salt is a corrosive substance that would result in rust stains if left to build up inside the oven. Acidic sauces, such as ketchup, mustard and preserves, contain chemicals like chlorine and acids which would damage its surface. So must clean the appliance every time after use.
10. The oven cavity color may change to yellow. It is because metal will generate yellow marks when heated. This is normal and will not affect the use of the oven or cause harm to human health.
11. Lack of proper cleaning, the appliance surface will be degraded to affect the product life and dangers may occur.
12. When store, put the oven in a box and store in a dry place.
13. When store, never wrap the power cord around the oven or put any pressure on the power cord, it is to avoid the power cord damage.

3. First Use

Before first use, operate the oven empty to eliminate the smell of new oven by the below procedures:

1. Take out all the accessories, rinse with clean water and dry up them.
2. Before connecting the oven to the power source, please check the function knob and timer knob are at OFF position.
3. Connect the power, set the temperature knob at 250°C, the function knob at , the timer knob at 10 minutes. When operate the oven empty, smoke, smell and noise may generate which is normal.
4. After operate the oven empty, must allow it cool down before use again.

4. Product Specifications

Model	REN-KMB21	REN-KMB22	REN-KMB25	REN-KGS28
Rated Voltage	220-240V~ 50/60 Hz	220-240V~ 50-60 Hz	220-240V~ 50/60 Hz	220-240V~ 50/60 Hz
Rated Power	1,380W	1,500W	1,500W	1,500W
Capacity (Approx.)	21 L	22 L	25 L	28 L
Temperature Control	Max.250°C (±30°C as normal range)			
Net Weight (Approx.)	5.9 kg	5.8 kg	6.0 kg	6.7 kg
Cavity Size* (W x D x H) (Approx.)	316 x 280 x 240 mm	324 x 285 x 256 mm	324 x 336 x 253 mm	347 x 295 x 265 mm
Product Size (W x D x H) (Approx.)	460 x 335 x 291 mm	463 x 356 x 308 mm	463 x 393 x 309 mm	498 x 365 x 328 mm

* The oven cavity size is calculated by measuring the maximum width, depth and height. The actual capacity for loading food is less.

5. Product Descriptions

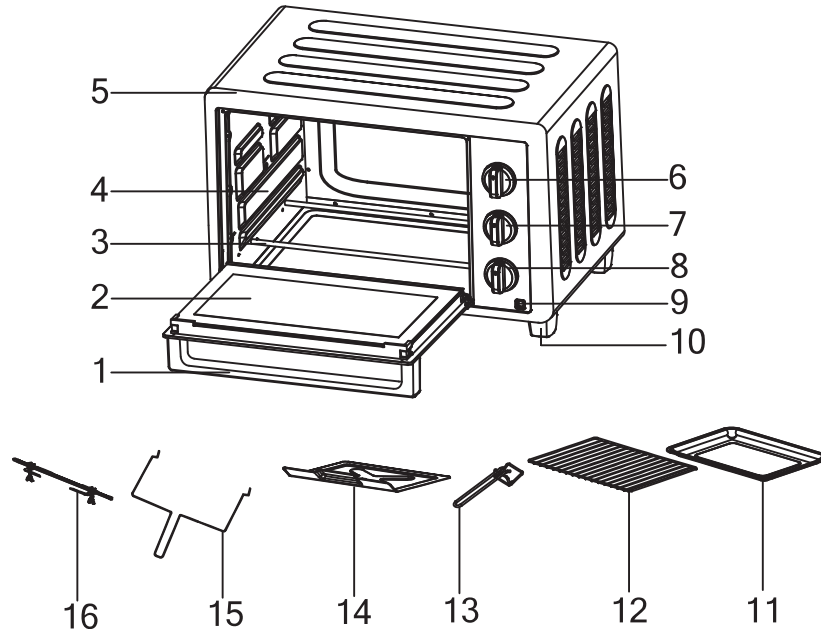

(All models are different in the appearance, but they have similar structure. Above product drawing is for reference only, please refer to actual product.)

1. Door handle: To open and close the oven door.
2. Door glass : Can see the food through the door to check the cooking status.
3. Heating element : To generate heat to cook food.

4. Tray rail: To hold the bake tray and grill rack.
5. Main body
6. Temperature knob: The temperature setting is 100°C-250°C.
7. Function knob :

OFF : Turn off the heating element.

 : Lower grill + convection.

 : Upper & lower grill.

 : Upper & lower grill + rotisserie + convection.

 : Upper grill + rotisserie.

 : Upper grill + convection.

8. Timer knob: Clockwise turn to set the desired time, the time setting is (OFF) 0-60 mins. End signal sound will be heard when finished the cooking.
9. Power indicator: It is controlled by the timer. The indicator light will be illuminated once the desired time is set. And it will be off at the end of the set time.

10. Oven foot

11. Bake tray: To hold juice or greasy food such as meat or seafood for baking. Suggested to fit a piece of aluminum foil onto the tray and then place food for baking, so that it can be cleaned easily. The maximum weight can be placed on the tray is 2.5kg (that includes total weight of food and dish.)

12. Grill rack: To hold dry food such as potatoes, bread and etc. The maximum weight can be placed on the tray is 2.5kg (that includes total weight of food and dish.)

13. Bake tray handle use to handle bake tray or grill rack. The using method is as follows :

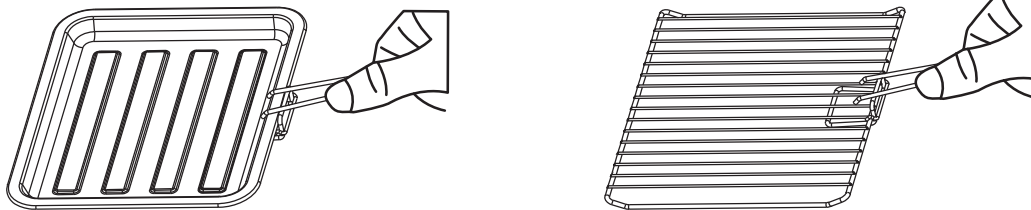



14. Removable crumb tray: Place under the bottom heating element, use to catch food residues and grease. Clean the crumb tray after each use. Otherwise, the residue will be over boiled, thus generating an odor.

15. Spit bracket : To take the rotisserie spit out.

16. Rotisserie spit (1pc rotisserie stick + 2pcs rotisserie forks + 2pcs screws): Use for rotisserie baking and the maximum weight of carrying food is 2.5kg.

6. Operation Instructions

1. Take out all the accessories and plug in the oven to the power socket. (Note: Pre-heat the oven for 10-15 minutes to obtain the optimum cooking performance.)
2. Put the food on the grill rack or bake tray evenly, then put into the oven at the desired level. If cooking food which is greasy or rich in sauce, wrap the food with aluminum foil first and put on the bake tray. When use the grill rack, make sure the foods do not leak through the rack, or you may use bake tray for food in small species. Close the oven door after settling the food.
3. Select the baking mode by rotating the function knob. Below are some suggestions for cooking food at different functions, you may adjust according to your personal experience.

Function	Suggestions for cooking food
	Baking bread, pizzas, meats and etc.
	Rotate roasting the poultry, skewers and etc.

When using the rotisserie, please be aware of the below points:

- 3.1 The rotisserie spit is sharp, use it carefully to avoid injury.
- 3.2 Insert a rotisserie fork into the rotisserie stick and rotate the screw to fix it at proper position.
- 3.3 Use the rotisserie stick to penetrate through the middle of the food and fix the food with the rotisserie fork at one side.
- 3.4 Insert another rotisserie fork into the rotisserie stick and interpose the food tightly. Rotate the screw to fix the rotisserie fork.
- 3.5 Use the spit bracket to place the penetrated food into the oven.
- 3.6 Insert the round end of the rotisserie spit into the right side rotation hole, then place the flat end of the rotisserie spit onto the rotisserie spit support, located on the left hand side of the oven wall.

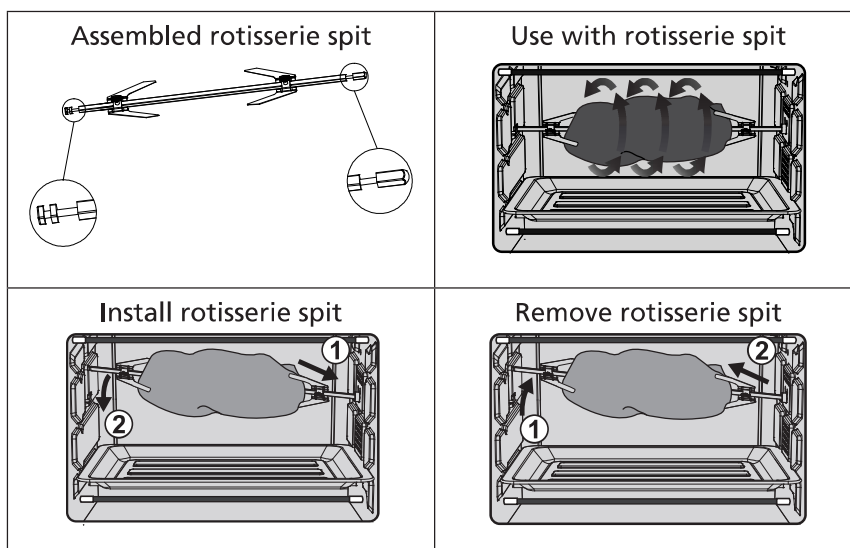

4. According to the food nature and personal preference, set the cooking temperature by rotating the temperature knob.
5. Set the timer knob to the required cooking time. The power indicator light will be on. If the cooking time is less than 5 minutes (e.g. 3 mins), please turn the timer knob over 6 minutes and rotate back to the required time.
6. When the cooking time is finished, it will have a signal sound. The timer knob will back to "OFF" position, please turn the function knob to "OFF" to switch off the oven. (Note: If you want to switch off the oven during cooking, turn the timer knob and function knob to "OFF" position manually.)
7. When checking or moving the food from the oven, please use oven gloves, bake tray handle or spit bracket to avoid burns.
8. After use, please unplug the oven from the power socket.

Notes on use:

- | |
|---|
| <ol style="list-style-type: none">1. Frozen food may take longer time to cook, please adjust the cooking time according to the actual cooking condition.2. The cooking time is varied with different food temperature, types, quantity etc. Please adjust it according to the actual cooking condition.3. Always pay attention to the food during cooking to avoid overcook.4. When cooking, water vapor may condense around oven door or on the door glass. This is because water evaporates from the food which is normal.5. To adjust the oven temperature, the heating elements are equipped with an auto power switching device. The heat elements will be off temporarily when the oven reaches the preset temperature and on again when the oven temperature declines. Do not remove the food during cooking, otherwise it may not be heated up adequately.6. There may be noise when the oven is operating, it is due to heat expansion of material and food, and it does not indicate any malfunction.7. If a large temperature change in the cooking process, overloaded or uneven food arrangement, it may cause the deformation of accessory. |
|---|

7. Special Avowal

1. The content in the operation manual has been checked. Our company reserves the hermeneutic power to any printing errors or misunderstanding on the content.
2. If there are technical improvements on the appliance, the operation manual will be updated in new version without prior notice. The product appearance and specification are subject to the manufacturer information.
3. In case there is any inconsistency or conflict between the English versions and Chinese versions of the terms, the Chinese versions shall prevail.
4. The e-copy of user manual can be sent by email on requested. For enquiries, please call Shun Hing Electric Works & Engineering Co., Ltd. hotline at 2861 2767.

8. After Sales Service

1. For any defect, in the judgement of technician from Shun Hing Electric Service Center Limited, caused under normal use, our company is responsible for repairing or replacing parts of the said electrical appliance free of charge within one year guarantee period commencing from the date of purchase. Any defect part which has been replaced shall become our property. Guarantee service does not cover the repair or replacement of consumable parts etc.
2. User must present the official invoice/redemption voucher and the product warranty card with the chop from sales point/redemption center for maintenance. For enquiries, please call Shun Hing Electric Service Center Limited hotline at 2406 5666.



Rasonic 樂信牌

信興電工工程有限公司

SHUN HING ELECTRIC WORKS AND ENGINEERING CO., LTD.

辦公室：香港九龍尖沙咀東部麼地道67號半島中心9樓

電話：2861 2767

圖文傳真：2865 6706

網址：<http://www.rasonic.com>

電郵：shew@shunhinggroup.com

Office: 9/F, Peninsula Centre, 67 Mody Road, Tsimshatsui East, Kowloon, H.K.

Tel: 2861 2767

Fax: 2865 6706

Website: <http://www.rasonic.com>

E-mail: shew@shunhinggroup.com

保養及維修 Maintenance and Repair Service:

信興電器服務中心有限公司

SHUN HING ELECTRIC SERVICE CENTRE LTD.

香港新界葵涌勝耀街2號信興中心11樓

電話：2406 5666

圖文傳真：2408 0316

網址：<http://www.shesc.com/zh>

11/F, Shun Hing Centre, 2 Shing Yiu Street, Kwai Chung, N.T. H.K.

Tel: 2406 5666

Fax: 2408 0316

Website: <http://www.shesc.com/en>

客戶服務中心

香港新界葵涌勝耀街2號信興中心1樓

九龍尖沙咀東部麼地道67號半島中心B座9樓

香港天后琉璃街7號柏景中心22樓

澳門慕拉士大馬路193-199號南嶺工業大廈5樓I座

Customer Service Centre

1/F, Shun Hing Centre, 2 Shing Yiu Street, Kwai Chung, N.T.

9/F, Block B, Peninsula Centre, 67 Mody Road, Tsim Sha Tsui East, Kowloon

22/F, Parkview Centre, 7 Lau Li Street, Tin Hau, Hong Kong

Avenida de Venceslau de Morais, No. 193-199,5 andar - 1, Edf. Industrial Nam Leng, Macau

有關最新之香港及澳門客戶服務中心資料，請參閱信興服務中心網址：<http://www.shesc.com/zh>

For the latest information of Hong Kong and Macau service center, please visit

<http://www.shesc.com/en>